

Incremental encoders

Through hollow shaft $\varnothing 80$ to $\varnothing 115$ mm
720...4.000 pulses per revolution

HOG 22



HOG 22

Technical data - electrical ratings

Voltage supply	9...30 VDC 5 VDC ± 5 %
Consumption w/o load	≤ 100 mA
Pulses per revolution	720...4000
Phase shift	$90^\circ \pm 20^\circ$
Scan ratio	40...60 %
Reference signal	Zero pulse, width 90°
Sensing method	Optical
Output frequency	≤ 120 kHz
Output signals	K1, K2, K0 + inverted
Output stages	HTL TTL/RS422
Interference immunity	EN 61000-6-2
Emitted interference	EN 61000-6-3
Approvals	CE, UL approval / E256710

Features

- Through hollow shaft $\varnothing 80$...115 mm
- Optical sensing method
- Robust light-metal housing
- Output stage HTL or TTL
- Output stage TTL with regulator UB 9...26 VDC
- Big terminal box, turn by 180°

Optional

- Redundant sensing (version M)
- Plug-in electronics with angle flange-connector

Technical data - mechanical design

Size (flange)	$\varnothing 227$ mm
Shaft type	$\varnothing 80$...115 mm (through hollow shaft)
Shaft loading	≤ 450 N axial ≤ 700 N radial
Protection DIN EN 60529	IP 54
Operating speed	≤ 3800 rpm (mechanical)
Operating torque typ.	50 Ncm
Rotor moment of inertia	102 kgcm ² ($\varnothing 100$)
Materials	Housing: aluminium Shaft: stainless steel
Operating temperature	-30 ... $+85$ °C
Resistance	IEC 60068-2-6 Vibration 10 g, 10-2000 Hz IEC 60068-2-27 Shock 200 g, 6 ms
Explosion protection	II 3 G Ex nA IIC T4 Gc (gas) II 3 D Ex tc IIIB T135°C Dc (dust)
Connection	Terminal box 2x terminal box (with option M) Plug-in electronics with angle-connector (option)
Weight approx.	8.6 kg ($\varnothing 100$)

Incremental encoders

Through hollow shaft $\varnothing 80$ to $\varnothing 115$ mm

720...4.000 pulses per revolution

HOG 22

Output signals

At positive rotating direction

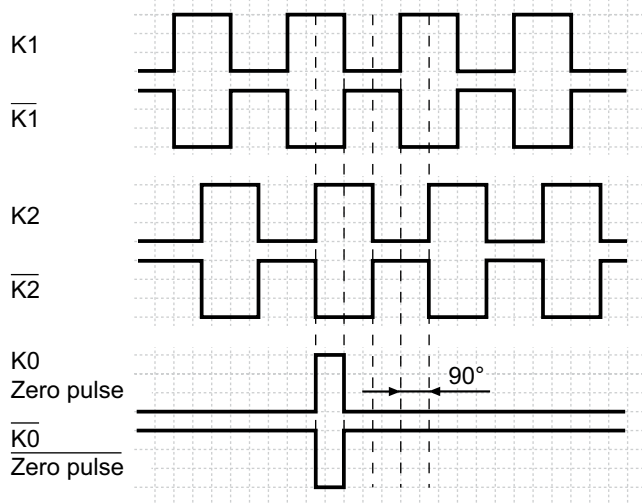

Terminal assignment

View A - Connecting terminal in terminal box

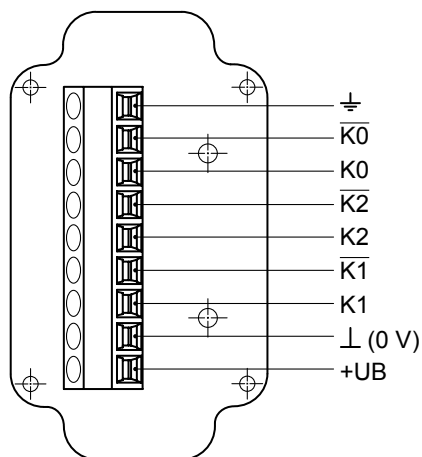

Incremental encoders

Through hollow shaft $\varnothing 80$ to $\varnothing 115$ mm
720...4.000 pulses per revolution

HOG 22

Dimensions

HOG 22 (HOG 22 M) - Version with radial terminal box

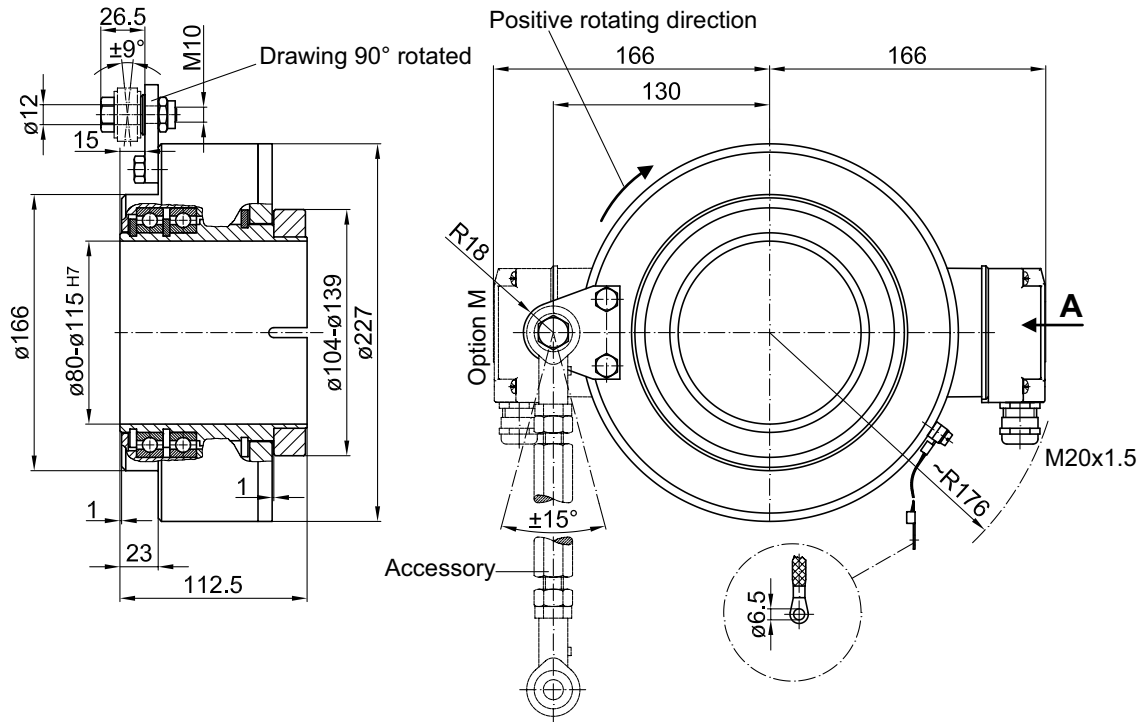

HOG 22 (HOG 22 M) - Version with plug-in electronics and angle-connector (option)

